

- > *gas flow*
- > *total consumption*

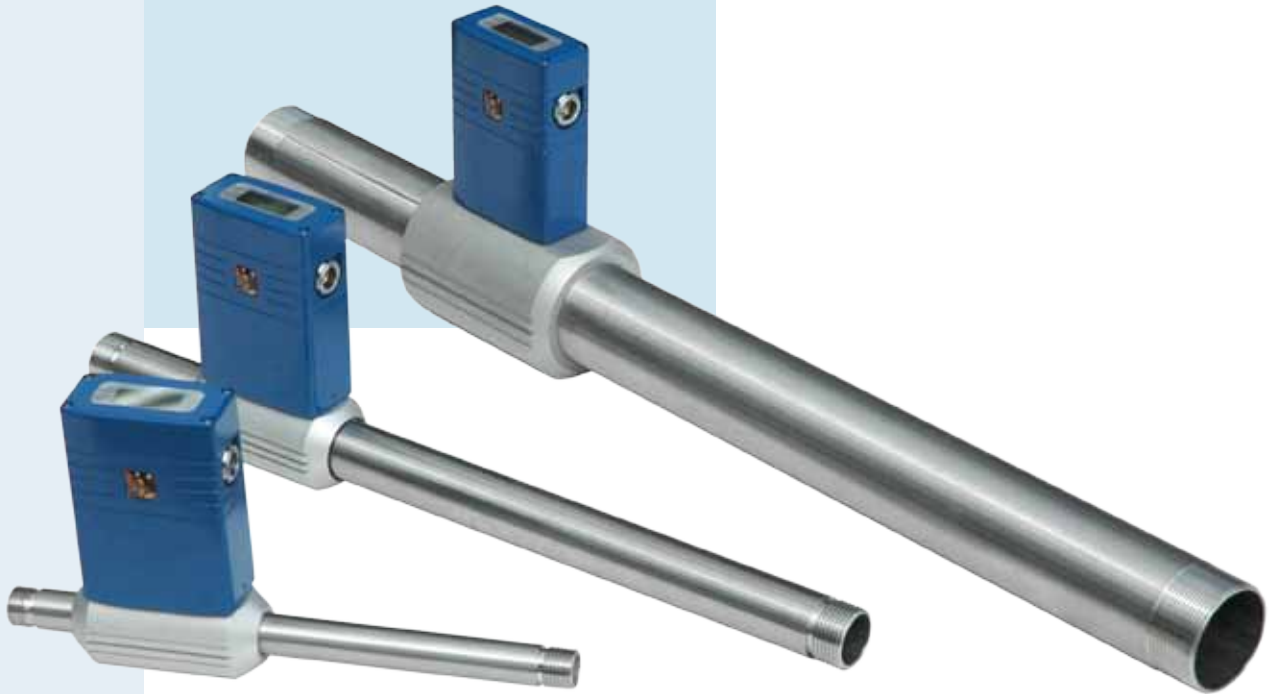

## **VPFlowMate®** in-line

*'If you can not measure it, you can not improve it'*  
(Lord Kelvin, 1883)

The VPFlowMate® in-line is the industrial proven mass flow meter. The VPFlowMate® can be used for flow measurements of compressed air and technical gasses. The display shows real-time read out of flow and the total consumption. The flow meter can be connected to most industrial equipment via RS232, 4..20mA or pulse. It can also be connected directly to the PC. Because of the high turndown ration and negligible pressure drop, the VPFlowMate® is suitable for many applications.



## Features:

- Direct view on actual consumption and total consumption.
- Available in three versions: 0.5", 1", 2".
- Analogue output and digital serial output for remote readings.



## Benefits:

- Plug and play.
- Quick and easy installation – no configuration necessary.
- Quick return on investment.

## Applications:

Leakage management, point-of-use measurement, cost allocation, testing of pneumatic systems.  
Ask for our applications form for more ideas!

## Customization:

Customize your VPFlowMate® in-line: start with the base unit and choose your accessories:

- Tubing kit, with in- and outlet piping.
- ISO calibration certificate.
- Cable.
- VPStudio real-time measurement software.

Accuracy: 5% f.s.	Accuracy: 1% f.s.	Accuracy: 0.5% f.s.	
VPFlowMate® Base	VPFlowMate® Base + Tubing kit	VPFlowMate® Base + Tubing kit + ISO Calibration certificate	

## Specifications:

Flow range:	Model	Range in m <sup>3</sup> <sub>n</sub> /hr	Range in l <sub>n</sub> /min	G (inch) connection
	VPF.R060.M050	60	1,000	0.5
	VPF.R200.M100	200	3,333	1
	VPF.R01K.M200	1,000	16,667	2
Temperature range:	0..50 °C			
Pressure range:	0..16 bar			
Humidity:	up to 95% relative humidity, non condensing			
Gases:	Compressed air, Nitrogen, inert gases			
Connection:	BSP			
Outputs:	RS232, 4..20mA, pulse			



**VPFlowMate®**  
in-line

VPFlowMate® in-line is a registered trademark of Van Putten Instruments B.V. Patents have been applied for and are pending.



**VP** INSTRUMENTS

Buitenwatersloot 335  
2614 GS Delft  
The Netherlands

T: +31 15 213 15 80  
F: +31 15 213 06 69  
I: [www.vpinstruments.com](http://www.vpinstruments.com)  
E: [info@vpinstruments.com](mailto:info@vpinstruments.com)